

2012 SKILLSUSA CHAMPIONSHIP

MOBILE ROBOTICS COMPETITION

Secondary

TEAM GUIDE

Contents

| | |
|--|----|
| 2012 SKILLS USA CHAMPIONSHIP | 1 |
| Acknowledgments..... | 3 |
| Mobile Robotics Technical Committee | 4 |
| Judges..... | 4 |
| National Educational Technical Committee | 5 |
| Awards | 5 |
| 1: Contest Overview | 7 |
| 1.1: Statement of the Problem..... | 7 |
| 1.2: Instructions..... | 8 |
| 1.3: Guidelines | 8 |
| 1.4: Kit of Parts | 9 |
| 1.5: Team Guidelines | 9 |
| 2: Official Competition | 12 |
| 2.1: Purpose..... | 12 |
| 2.2: Clothing Requirement..... | 12 |
| 2.3: Eligibility | 12 |
| 2.4: Scope of Contest..... | 12 |
| 2.5: Group Organizational Goal..... | 15 |
| 2.6: Engineering Notebook | 15 |
| 2.7: Required Materials..... | 17 |
| 3: Safety | 19 |
| 4: Additional Forms | 20 |
| Appendix A – SkillsUSA VEX Robotics Kit Bill of Materials..... | 22 |
| Appendix B – Field Information..... | 24 |
| Appendix C – State Competitions..... | 30 |

Acknowledgments

The success of the competition is the result of the motivated contestants and their instructors, the determined efforts of the National and State Technical Committees, and the generosity of companies donating equipment. The following companies have contributed resources and support.

intelitek, Inc.
AZTECH Educational Resources
Caterpillar
Holmquist Educational Consultants, Inc.
Solidworks
VEX Robotics, Inc.
Robotics Education and Competition Foundation
Honeywell

Mobile Robotics Technical Committee

The following individuals contributed their time and energy to the Technical Committee:

Secondary Competition

Dan Larochelle
intelitek, Inc.

Rick Knisely
AZTECH Educational Resources

Paul Copioli
VEX Robotics, Inc

Stephanie Holmquist
Holmquist Educational Consultants, Inc.

Rick Folea
Robotics Education and Competition
Foundation

Judges

The following individuals contributed their time and energy as Judges for the competition:

Tom Hand
Honeywell

Emma Hand
Honeywell

John V-Neun
VEX Robotics

National Educational Technical Committee

The following individuals contributed their time and energy to the National Educational Technical Committee.

Dr. Jeanea Lambeth Engineering Teacher
Camelback High School, Phoenix, AZ

Martin Bencic, CTE Program Coordinator
Peoria Unified School District, Peoria, AZ

Dr. Lora Zimmer, Engineering Teacher
Moon Valley High School, Phoenix, AZ

Roger Osgood, National Education Chair
John E. Dwyer Technology Academy

Awards

The following companies have supplied awards:

Intelitek, Inc.
Solidworks
VEX Robotics, Inc.
Lowe's

2012 SkillsUSA Mobile Robotics Competition

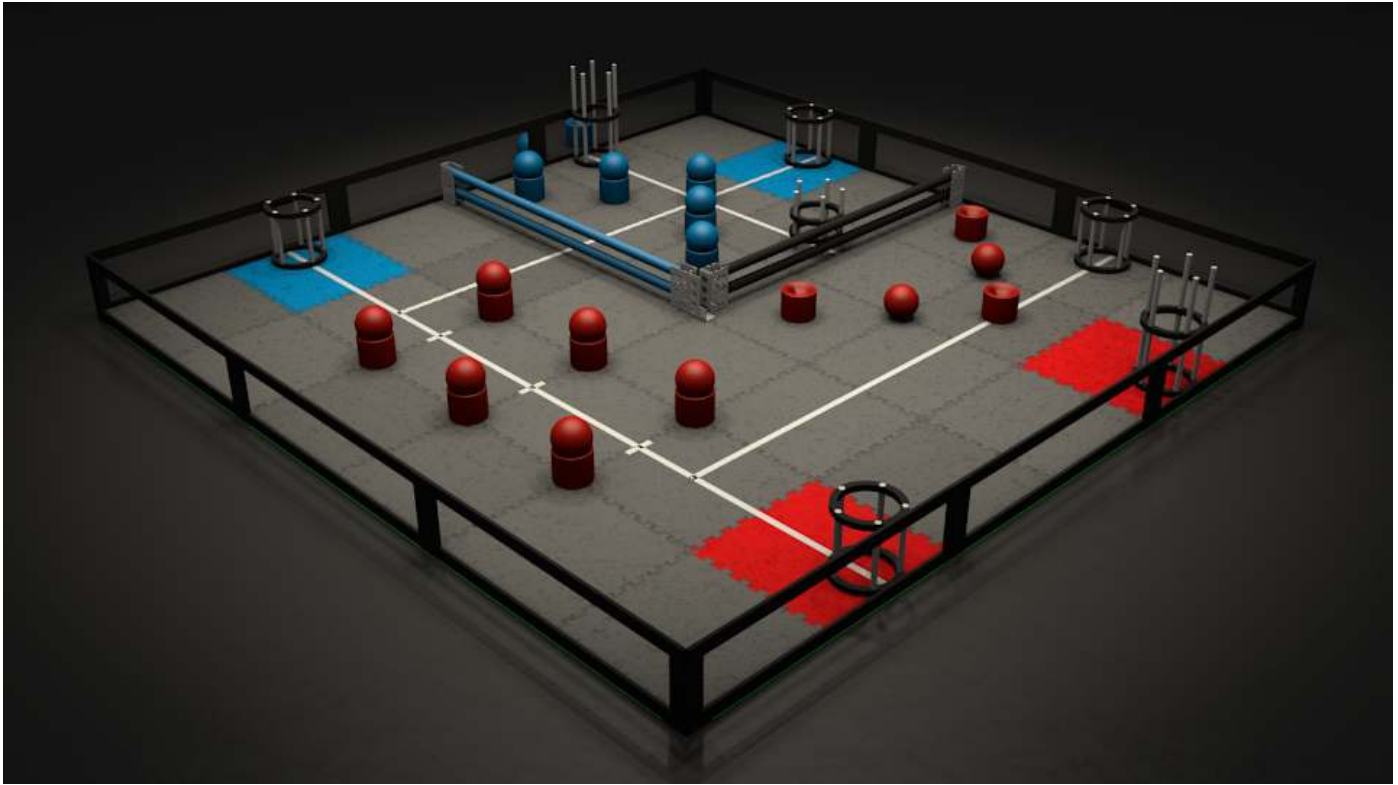

The Game

In this year's challenge, teams are tasked with moving 6" diameter balls and barrels into goals distributed across the field during a two minute autonomous and operator control round.

The Field

The 12' x 12' field contains 13 balls and 14 barrels. Teams may preload up to one additional ball and barrel. A stationary fence and a moveable gate create an isolation zone where the robot begins the round. Six goals are scattered around the field: one tall goal and one short goal in the isolation zone, and one tall goal and three short goals on the rest of the field. White tape lines cross the field. There are four colored tiles on the playing surface: two red and two blue.

The Round

A team's robot begins the round touching the blue tile in the Autonomous Zone. For the first 60 seconds of the round, the robot operates completely autonomously. Using sensors and pre-programmed instructions, the robot must attempt to put as many blue game pieces into goals or out of the Autonomous zone as possible. At the end of autonomous, the robot is removed from the Autonomous zone and the gate is closed. During next 60 seconds of the round, drivers take control of the robot. Teams score points for each game object scored in a goal, or touching a colored tile.

Scoring

Blue Object Scored in a 20" Goal: 10 Points
Blue Object scored in a 11.5" Goal: 5 Points
Red Object Scored in a 20" Goal: 5 Points
Red Object Scored in a 11.5" Goal: 3 Points
Any Object Touching a Colored Tile: 1 Point

1: Contest Overview

Cutting-edge Technology

Many believe that in the future, robotics will encompass every part of life. Even today, robots do the jobs that people find dull, dirty or dangerous. To compete in this evolving field, companies will be looking for individuals who are fluent in mechanical design, electrical systems and robot programming. Additionally, working well in a team with diverse skills is important to success in the robotics industry. With today's complex design and engineering challenges, no individual is equipped with all the answers to any robotics problem.

Your Team

Success in a Mobile Robotics Competition is often found using a team approach. In the interest of emulating industry, this competition will be structured in this manner. For optimum team efficiency, we suggest your team be comprised of a specialist in each of the following fields:

- Mechanical Design
- Mobile Robotics Programming

1.1: Statement of the Problem

1.1.1: The Client's Needs

The Springfield Amusement Park (hereafter referred to as the client) is looking to improve on its garbage handling process. Normally, employees of the client would collect the waste from each of the trash receptacles in the amusement park as well as in the parking lot and deposit it into dumpsters located throughout the property. However, this is a time consuming process that places the employees at risk for back, neck and other injuries. Additionally, none of the employees enjoy the smell of garbage.

1.1.2: Your Assignment

As a Mobile Robotics development team, known as D&F Robotics, your task is to create a mobile robot that can retrieve garbage from trashcans and move it to dumpsters located around the client's property both autonomously and while under human operation. During the night, the robot must move autonomously around the property to collect the garbage. After a certain period of time, however, the robot must be brought behind the main gate before the employees leave for the night. The next morning under human control, the robot will go around the interior of the park to collect the remainder of the garbage.

1.2: Instructions

1.2.1: Initial Design

The Client is an amusement park that is looking for an automated way to move garbage to dumpsters. Currently, the Client is able to give you a layout of the property, along with some general robot operating guidelines. The robot must autonomously move garbage into dumpsters, and then move behind the gate during the overnight. The next day, the robot must transition into an operator controlled garbage vehicle. Your team's job is to create a robot that can do these tasks.

The Client requires that each stage of the design, fabrication, and programming process be well-documented. This includes a bill of materials, assembly instructions, a code flowchart, and a printed, final program for the robot.

After your prototype has been designed, programmed and assembled, you will test the robot in a simulation of the Client's facility.

1.2.2: Concurrent Engineering

The Client will review the prototype and may require one or more changes. Be prepared to handle different configurations of trash that may need to be moved at different times. Having a robot that can handle diverse challenges will make your design more appealing to the Client.

1.3: Guidelines

1.3.1: Requirements

The Client's Engineering Project Manager has provided an outline of materials to begin your planning and manufacturing process. Your success on this project is based upon the following criteria:

1. Teams must be composed of two members.
2. Teams are given a task that they will solve using a mobile robotic system provided by the technical committee.
3. During the orientation session, each team will have 10 minutes to present their solution to the problem to the judges.
4. Teams can only bring an Engineering Notebook and a laptop to the contest as reference tools in the construction and programming of their robot. The laptop is allowed to have code already on it for their planned solution to the problem.
5. The Engineering Notebook is a tool for students to document their designs prior to the competition. It can include pictures, printed sections of code, detailed assembly instructions, etc. All pages must be bound and numbered.
6. The Robot can only be constructed from materials supplied by the technical committee.
7. Once a team has performed the required task or set of tasks, a design change may be introduced.
8. Contestants are required to adhere to industry safety standards using the hardware and software provided.
9. All team members are responsible for double-checking each other's work and quality control.
10. All engineering notebooks, forms, documentation and programs must be turned in to the judges at the end of the competition.
11. All team members and advisors are required to attend a debriefing session after the competition has concluded.

1.4: Kit of Parts

1.4.1: Kit of Parts Overview

Your robot may only be made of components listed on the SkillsUSA kit of parts. A full list is available in Appendix A

1.5: Team Guidelines

1.5.1: Challenge Rules

These are the official rules and guidelines for the Mobile Robotics Competition. All teams will be expected to adhere to these rules.

1.5.1.1: Definitions

- **Autonomous Period:** A 60 second period in which robots operate only based on pre-programmed instructions and sensor inputs. Team members are not allowed to interact with the robot during this period.
- **Driver Control Period:** A sixty second period in which robots are operated by team members through a wireless transmitter.
- **Ball:** A blue or red spherical shaped plastic scoring object with a diameter of six inches.
- **Barrel:** A blue or red cylindrical shaped plastic scoring object with a diameter of six inches and a height of five inches.
- **Circular Goal:** One of the six circular shaped field structures, into which team place balls or barrels. The goals are 11.5” and 20” high. The circular goal consists of two retaining rings and five PVC pipes. The outer edge of the ring is considered to be the outer edge of the circular goal.
- **Autonomous Zone:** The six foot by six foot area of the field defined by the gate, a black PVC pipe wall and the field perimeter.
- **Gate:** The blue PVC field element that separates the Autonomous Zone from the rest of the field. **The gate starts the round open, allowing access to the entire field.**
- **Colored Foam Tile:** A foam floor tile colored either red or blue.

1.5.1.2: Field Setup

- The field is 12' by 12', enclosed by an 11.5" tall field border.
- The surface of the field is comprised of grey, red, and blue foam tiles.
- There are 14 Barrels and 13 balls on the field. Of these, five barrels and five balls are blue, while the remaining pieces are red. In addition, there is one blue barrel and one blue ball available for preloading into the robot before the start of the round.
- There are six Circular Goals; two are 20” tall, while 4 are 11.5” tall. See appendix B for a field layout.
- Four colored tiles are located around the field. See Appendix B for information on the field layout.

1.5.1.3: Scoring

- A ball or barrel is legally scored if it is not touching the robot and meets only one of the following criteria:
 1. The ball or barrel is fully below the top of the PVC pipes of a Circular Goal and fully within the outer ring of the Circular Goal.
 2. The ball or barrel is not fully below the top of the PVC pipes of a Circular Goal and it is partially within the outer ring of the Circular Goal and is not within the outer ring of any other Circular Goal.
 3. Any part of the ball or barrel is touching any part of a colored foam field tile and not within the outer ring of a Circular Goal.
- At the end of Operator Control, points will be given out as follows:
 - 1 point for each ball or barrel scored on a colored tile (meeting only the third criteria for scoring)
 - 3 points for any red ball or barrel scored in a 11.5” goal
 - 5 points for any red ball or barrel scored in a 20” goal
 - 5 points for any blue ball or barrel scored in a 11.5” goal
 - 10 points for any blue ball or barrel scored in a 20” goal

1.5.1.4: Match Sequence

- 0-60 Seconds: Autonomous Period.
- 60-120 Seconds: Operator Period.

1.5.1.5: Game Play Rules

- Each round will be two minutes long and will feature only one robot.
- Teams may begin a round with up to one blue ball and one blue barrel preloaded into their robot. A ball or barrel is legally preloaded if it is touching the robot or touching another legally preloaded ball or barrel. If a team chooses to not preload a blue ball or barrel before the start of the round, these objects cannot be introduced to the field during the round.
- Balls or Barrels that leave the field will be promptly returned to the field by event personnel at the location nearest the point at which they exited.
- During a round, robots may be remotely controlled only by the drivers and by software running on the control system. If any team member touches his or her team's robot anytime during a round, the robot will be disabled and the team disqualified from that round.
- Scores will be calculated once all robots and field elements come to rest.
- Robots must start the round touching the blue field tile in the Autonomous Zone.
- At the end of autonomous, the Gate will be lowered. If a robot is still within the Autonomous Zone, or it is touched by the gate as it is being lowered, the team must place their robot in its current

configuration such that it is touching the blue field tile outside of the Autonomous Zone, and the operator period will be shortened to 50 seconds.

- Robots may not drive on the playing surface of, or touch any game objects in the Autonomous Zone during driver control. Violations of this rule will result in the team being disqualified from that round.

1.5.1.6: Robot Rules

- Robots must be no larger than 18" by 18" by 18" at the start of a round. They may expand to any size once the round has begun. If the robot exceeds this starting size, it will not be allowed to compete.
- Robots may only be constructed from the same type and quantity of parts found in the SkillsUSA VEX Robot Kit or additional, approved non-VEX materials, and only after the challenge has been released to teams. See Appendix A for a list of parts found in the SkillsUSA VEX Robotics Kit.
- No robot may have mechanisms that could potentially damage the playing field or field elements, or pose a safety hazard to teams or spectators.
- All parts of the robot must remain attached to the robot for the duration of the round. Any infraction of this rule may result in an immediate disqualification. Minor pieces that unintentionally become detached from the robot, or are the result of improper design /construction will not cause a disqualification
- Teams may not modify any part of the control system or any motor or servo.
- Robots are allowed only the following non-VEX components:
 - Any parts which are identical to legal VEX parts, such as screws, zip ties etc.
 - Any non-functional decorations that do not affect robot performance.
 - Commercial threadlocker may be used only to help secure fasteners.

1.5.2: Field Malfunctions

IN THE CASE OF A FIELD FAILURE: The team leader will communicate the problem to a representative of the Technical Committee. The representative will then notify the Project Manager. If it is determined that it is in fact a field problem, the round will be replayed. In the case of a replayed round, the previous score will not be counted and the team's new round score will count, regardless of whether the team scores more or less points.

IN THE CASE OF PROGRAMMING PROBLEMS: A robot's program is the responsibility of the team. All software must be original copies. If your team develops a problem with your software or robot program, the Technical Committee will work in whatever way it can to resolve the problem but no rounds will be replayed due to problems with the robot's program.

2: Official Competition

2.1: Purpose

2.1.1: Goals of the Competition

- To evaluate each contestant's preparation for employment in fields related to mobile robotics and the team approach to problem solving in the work environment.
- To recognize outstanding students for excellence and professionalism in the field of mobile robotics.

2.2: Clothing Requirement

2.2.1: Correct Attire

For men: Official SkillsUSA white polo shirt with black dress slacks, black socks and black leather shoes.

For women: Official SkillsUSA white polo shirt with black dress slacks or skirt, black socks or black or skin-tone seamless hose, and black leather shoes.

All: Safety glasses with side shields or goggles. Prescription glasses can be used only if they are equipped with side shields. If not, they must be covered with goggles.

These regulations refer to clothing items that are pictured and described at: www.skillsusastore.org. If you have questions about clothing or other logo items, call 800-401-1560 or 703-956-3723.

Note: Contestants must wear their official contest clothing to the contest orientation meeting.

2.3: Eligibility

2.3.1: Qualifications

Open to a team of two active SkillsUSA members enrolled in programs in a career and technical education engineering program or program that integrates robotics, engineering or pre-engineering techniques as an integral component of the instructional program.

2.4: Scope of Contest

The contest will test the ability to perform, exhibit and compile skills and knowledge from the following list of competencies determined by the SkillsUSA Mobile Robotic technical committee. Committee membership includes intelitek, Inc., VEX Robotics, Inc., AZTECH Educational Resources, the REC Foundation, and Holmquist Educational Consultants.

Knowledge Performance

The contest will include a written exam assessing general knowledge of robotics operations and programming. Written portions may also exist during the skills portion of the contest.

Skill Performance

The contest will include activities that simulate situations encountered by robotic programmers and support professionals.

2.4.1: Teams and Documentation

1. Teams **MUST** be composed of only two members. Teams will demonstrate their ability to perform, utilize skills and knowledge necessary to complete the project as presented to them by the Technical Committee.
2. Your team is presented with a game challenge with which to design and prototype a robot. You will then be asked to assemble this robot at the event. When you finish the robot, you will participate in a number of rounds. Your scores will be tallied and points will be awarded. After your two rounds, an engineering change order will be introduced.

2.4.2: Competencies

MR 1.0 - Demonstrate knowledge in safety rules and practices

- 1.1 Maintain a safe work area
- 1.2 Demonstrate correct use of hand tools
- 1.3 Follow safety rules during robotic assembly
- 1.4 Demonstrate proper use of safety equipment
- 1.5 Define and document all safety issues

MR 2.0 - Produce technical documentation

- 2.1 Maintain a professional engineering notebook
- 2.2 Document assembly instructions with illustrations
- 2.3 Produce a Bill of Materials (BOM)
- 2.4 Document the engineering design process

MR 3.0 – Apply knowledge of robotic assembly and part identification

- 3.1 Identify various parts used on a mobile robot (wheels, motors, gears etc.)
- 3.2 Identify the various systems in a mobile robot
- 3.3 Demonstrate the use of various components of a mobile robot
- 3.4 Demonstrate proper assembly techniques

MR 4.0 – Understand mechanical systems of a mobile robot

- 4.1 Understand and identify the various types of gears and their application
- 4.2 Demonstrate the use of gears on a mobile robot
- 4.3 Understand and identify the various types of chain and sprocket mechanisms
- 4.4 Demonstrate proper mechanical component alignment.

MR 5.0 - Wire a mobile robot

- 5.1 Demonstrate proper wiring techniques
- 5.2 Maintain and analyze battery voltage
- 5.3 Understand and use multiple types of mobile robotic sensors
- 5.4 Understand and differentiate different types of motors and motor controllers

MR 6.0 - Produce examples of basic computer programming and flowcharting

- 6.1 Draw a programming flow chart representing a robot program for a given scenario
- 6.2 Develop a basic computer program to control robot
- 6.3 Manipulate feedback from robotic sensors in a program
- 6.4 Demonstrate proper commenting of code in a mobile robot program

MR 7.0 - Presenting technical information and technical problem solving

- 7.1 Demonstrate the knowledge of various visual aids used to present technical information
- 7.2 Present technical material in a professional manner
- 7.3 Demonstrate proper presentation techniques
- 7.4 Define team roles and responsibilities
- 7.5 Demonstrate ability to solve problems as a team in a given time frame
- 7.6 Demonstrate and document a comprehensive plan to solve an engineering problem
- 7.7 Use of proper time management when solving a problem
- 7.8 Demonstrate efficient project management and planning

MR 8.0 – Identify communication protocols for mobile robots

- 8.1 Understand basic communication techniques in mobile robotics
- 8.2 Demonstrate proper communication between a transmitter and a robot

2.5: Group Organizational Goal

2.5.1: Team Dynamics

The competition should run much like you would expect from industry, with group members interacting at will. The mechanical expert will lead in the robot construction while the programmer will lead the robot programming.

The contest is designed to promote creativity in organization of production responsibility. Teams should divide duties among all team members. No one individual should dominate by taking responsibility for more than one project specialty. When a team member has spare time, they will help their teammates. All Team members are responsible for double-checking each other's work and quality control.

2.5.2: Team Objectives

1. To have every team complete the competition.
2. To have each team member demonstrate reading and writing skills.
3. To have each team member use their critical thinking and problem solving abilities in the contest.
4. To have each team member illustrate responsibility, teamwork, self-management skills, and professionalism.

2.6: Engineering Notebook

2.6.1: Oral Presentation

Each team will have ten minutes to present their solution to the problem and their Engineering Notebook to the judges. Teams may bring additional support materials such as PowerPoint Presentations, posters etc. A projector and screen will be available to all teams. Teams must supply their own laptops for their presentation.

2.6.2: Parts of the Engineering Notebook

Note: The Engineering Notebook will be submitted for judging prior to the assembly portion of the event.

Overall Appearance and Professionalism (50 Points Available):

The Engineering Notebook will be judged on format, organization, and presentation. For information on formatting and content of an engineering notebook, visit http://www.bookfactory.com/special_info/engr_notebook_guidelines.html.

Bill of Materials (50 Points Available):

Each team will be required to list all of the materials used on their robot, both in type and quantity.

Assembly Instructions (50 Points Available):

Teams are encouraged to create detailed assembly instructions for their robot prior to arriving at the competition.

Illustrations of Design Process (50 Points Available):

Teams are encouraged to include pictures and sketches of their design process in their Engineering Notebook.

Program Flow-Chart (50 Points Available):

Teams are encouraged to include a flow-chart of their robot's program in their Engineering Notebook. This chart does not require actual portions of code, but should be a general overview of how the program flows. For more information on proper flow-chart technique, visit http://en.wikipedia.org/wiki/Flow_chart.

Printed Program for Robot (50 Points Available):

Teams should print their code and include it in the Engineering Notebook. This program should follow the team's flow-chart. This does not need to be the final robot program; however teams are encouraged to make their program as complete as possible ahead of time to maximize their score.

2.7: Required Materials

2.7.1: Workstation Components

Teams require the following materials to complete the competition. The Technical Committee provides many of these materials, but the teams must also bring certain items.

The Technical Committee provides:

1. Design Challenge field and scoring objects
2. General workspace for teams to cut materials, including vises and a hacksaw
3. Two 8 ft conference tables
4. One standard 120V electrical outlet
5. Description of mobile robotic design challenge
4. SkillsUSA Robotics Kit of Parts (VEX Robotic Design System)
5. A printer

2.7.2: Team Provided Components

Teams will provide the following:

1. Engineering Notebook
2. Safety glasses and work gloves
3. Rotary tool with appropriate attachments (safety glasses required)
4. Drill and drill bits
5. Allen wrench set (English)
6. Aircraft Snip for cutting VEX metal
7. A laptop with licensed VEX programming software (for the Cortex microcontroller) and presentation software
8. Power strip and extension cord
9. Calculator (standard, scientific or graphing)
10. Tape measure and/or ruler
11. Hammer
12. Phillips and slotted screwdrivers
13. Metal File
14. Pliers

15. Permanent black marker

16. Graph paper, pens, pencils, tape, electrical tape, and scissors

Note: ONLY the above listed items will be allowed in the contest area during the competition.

3: Safety

3.1: Importance of Safety

To maintain an effective and competitive company, it is in the best interest of both employer and employee to maintain a safe work environment. When a company's history of incidents resulting in injury is minimal, the company increases its likelihood of reduced insurance rates and workman compensation fees.

Safety considerations are taken into account during judging to further replicate a professional industrial environment.

3.2: Safety Violations

If a team or a team member violates a safety rule, or operates their robot in an unsafe manner, the following penalties will be enforced:

1st Violation:

Team will be issued a written warning.

2nd Violation

Team will have 50 points deducted from their total score.

3rd Violation

Team will be disqualified.

3.3: Avoiding Safety Hazards

Some safety issues:

1. Team members must keep their work area reasonably clean. Clean work places promote efficient and safe working conditions. Special attention should be paid to keeping the floor clean.
2. Team members must keep their teammates and other teams aware of possible dangerous situations, such as pinch points, sharp edges and the enabling of robots.
3. Team members must wear safety glasses when they on the playing field and while they are in their work area.
4. Tampering with or dismantling of any part of the supporting equipment (e.g., computers, printers, etc.) is a direct safety violation, and can be grounds for immediate disqualification.

4: Additional Forms

4.1: Document Submission

The following documentation must be prepared by teams for judging.

- Engineering Notebook
- Math Problem

SKILLSUSA
Mobile Robotics
JUDGING FORM 2011

| | MAXIMUM POINTS | CHECK | POINTS AWARDED |
|--|------------------------|-------|-------------------|
| Presentation | | | |
| 1. Oral Presentation | 50 | | |
| 2. Presentation Support Materials | 50 | | |
| Presentation Subtotal | 100 | | |
| Engineering Notebook | | | |
| 1. Overall Appearance and Professionalism | 50 | | |
| 2. Bill of Materials | 50 | | |
| 3. Assembly Instructions | 50 | | |
| 4. Illustrations of Design Process | 50 | | |
| 5. Program Flow Chart | 50 | | |
| 6. Printed Program for Robot | 50 | | |
| Engineering Notebook Subtotal | 300 | | |
| Robotic Task Performance | | | |
| 1. Rounds one and two Score | 300 | | |
| Robotic Design Challenge Performance Subtotal | 300 | | |
| Concurrent Engineering | | | |
| 1. Rounds three and four Score | 150 | | |
| 2. Area Clean and Organized | 50 | | |
| Concurrent Engineering Performance Subtotal | 200 | | |
| Math Problem | 100 | | |
| Safety (deductions) | | | |
| GRAND TOTAL | <u>1000 pts</u> | | |

Appendix A – SkillsUSA VEX Robotics Kit Bill of Materials

| Item | Quantity |
|---------------------------------|----------|
| Cortex Microcontroller | 1 |
| VEXnet Joystick | 1 |
| VEXnet 802.11 Key | 2 |
| VEXnet Backup Battery Holder | 1 |
| USB A-A Cable | 1 |
| Jumper Clip | 5 |
| Cable, PWM Extension, 12" | 4 |
| VEX Programming Cable | 1 |
| Bumper Switch | 2 |
| Limit Switch | 2 |
| Line Following Sensor | 3 |
| Ultrasonic Sensor | 1 |
| Potentiometer | 2 |
| Optical Shaft Encoder | 2 |
| 2-Wire Motor 269 | 4 |
| 2-Wire Motor 393 | 2 |
| Motor Controller 29 | 6 |
| 4" Wheel | 4 |
| 4" Omni-Directional Wheel | 4 |
| 4" High Traction Tire | 4 |
| 2.75" Wheel | 4 |
| 2.75" Omni Directional Wheel | 4 |
| Intake Roller | 4 |
| Double Bogie Wheel Assembly | 4 |
| Single Bogie Wheel Assembly | 2 |
| Tank Tread Drive/Idler Wheels | 4 |
| Tank Tread Link | 170 |
| Tank Tread Traction Link | 25 |
| Conveyor-Belt Base Link | 30 |
| Short Conveyor Belt Insert | 10 |
| Medium Conveyor Belt Insert | 10 |
| Tall Conveyor Belt Insert | 10 |
| High Strength Chain Links (48") | 140 |
| HS Chain Attachment Link | 20 |
| 6-tooth HS Sprocket | 4 |
| 12-tooth HS Sprocket | 2 |
| 18-tooth HS Sprocket | 2 |
| 24-tooth HS Sprocket | 2 |
| 30-tooth HS Sprocket | 2 |
| HS 12-Tooth Gear | 4 |
| HS 36-Tooth Gear | 4 |
| HS 60-Tooth Gear | 4 |
| HS Square Gear Insert | 16 |

| | |
|------------------------------------|----|
| HS Free Spinning Gear Insert | 16 |
| Differential Frame | 1 |
| 12-Tooth Pinion Gear | 2 |
| 19-Tooth Rack Gear | 8 |
| Worm Wheel | 4 |
| Worm Gear | 4 |
| 24-Tooth Bevel Gear | 7 |
| 12-Tooth Gear | 5 |
| 36-Tooth Gear | 4 |
| 60-Tooth Gear | 4 |
| 84-Tooth Gear | 2 |
| Bearing Flat | 67 |
| Pillow Block | 6 |
| Plastic Lock Bar | 4 |
| Drive Shaft Bar Lock, Metal | 16 |
| Shaft Collar | 49 |
| 12" Shaft | 6 |
| 2" Shaft | 13 |
| 3" Shaft | 12 |
| 11mm Motor Shaft | 6 |
| Latex Tubing | 1 |
| Chassis Bumper (25-Hole) | 2 |
| Chassis Bumper (15-Hole) | 2 |
| Chassis Rail (16-Hole) | 4 |
| Chassis Rail (25-Hole) | 4 |
| C-Channel, 1x2x1x35 Hole | 6 |
| C-Channel, 1x5x1x35 Hole | 5 |
| VEX Claw Assembly | 1 |
| Angle 3x3x35 | 4 |
| Segmented Angle 1x1x35 | 6 |
| Slotted Angle, 30-Hole | 5 |
| Slotted Angle, 30-Hole, INVERSE | 1 |
| Linear Slide | 2 |
| Bar, 25-Hole | 10 |
| Plate, 5 x 15 Hole | 4 |
| Plate, 5 x 25 Hole | 2 |
| Angle Gussets | 4 |
| Pivot Gussets | 4 |
| Plus Gussets | 4 |
| Rack Gearbox Bracket | 2 |
| Hinge | 2 |
| 1" Standoffs | 16 |
| 1/2" Standoffs | 24 |

| | |
|-----------------------------------|-----|
| 2" Standoffs | 8 |
| 3" Standoffs | 8 |
| 5" Standoff | 4 |
| Screw, 6-32 x 1/4" Long | 32 |
| Screw, 6-32 x 1/2" Long | 16 |
| Screw, 8-32 x 1/4" Long | 78 |
| Screw, 8-32 x 3/8" Long | 136 |
| Screw, 8-32 x 1/2" Long | 32 |
| Screw, 8-32 x 5/8" Long | 100 |
| Screw, 8-32 x 3/4" Long | 14 |
| Screw, 8-32 x 1" for Bogie wheel | 12 |
| Threaded Coupler 8-32 x 1/2" Long | 25 |
| Nut, 8-32 Keps | 307 |
| Nut, 8-32 Nylock | 114 |
| Spacer (4.6mm) | 40 |
| Spacer (8mm) | 40 |

| | |
|------------------------------------|-----|
| Spacer, Nylon, 0.125 | 10 |
| Spacer, Nylon, 0.250 | 10 |
| Spacer, Nylon, 0.375 | 10 |
| Spacer, Nylon, 0.500 | 10 |
| Plastic Washer | 12 |
| Steel Washer | 30 |
| Rubber Link 8-32 | 4 |
| #32 Rubber Band | 20 |
| 4" Zip Tie | 100 |
| 7.2V Robot Battery NiMH 3000mAh | 2 |
| Battery Strap | 4 |
| AAA NiMH Rechargeable Battery | 12 |
| 8-Bay AA/AAA Smart Charger | 1 |
| Smart Charger with Power Cord | 1 |
| Safety Glasses | 2 |

Appendix B – Field Information

Field Pictures

Front View

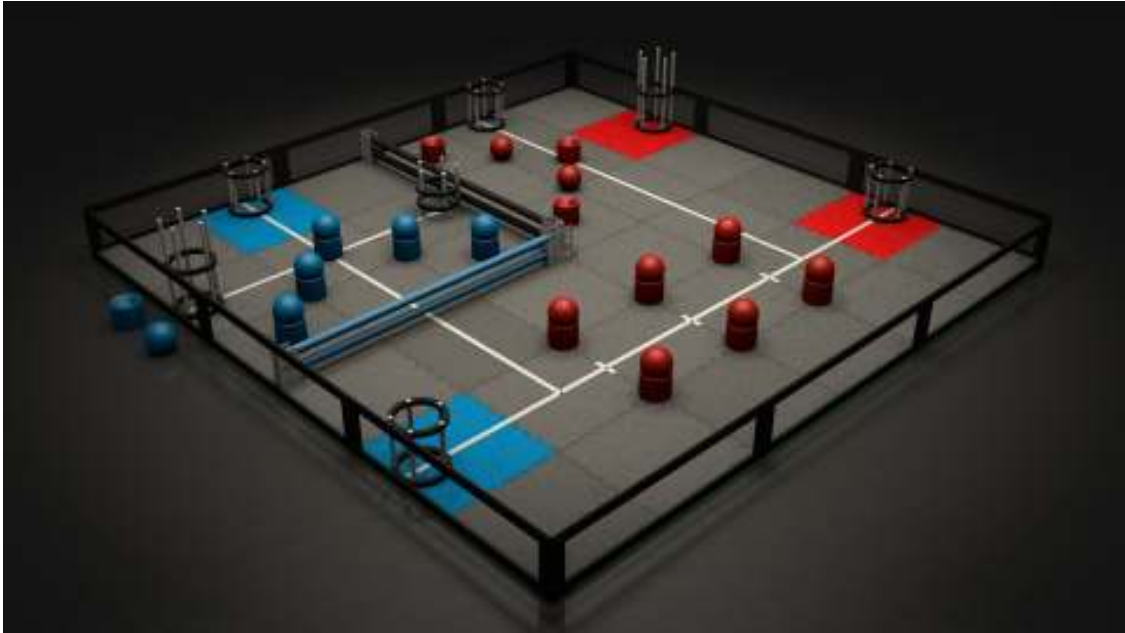

Side View

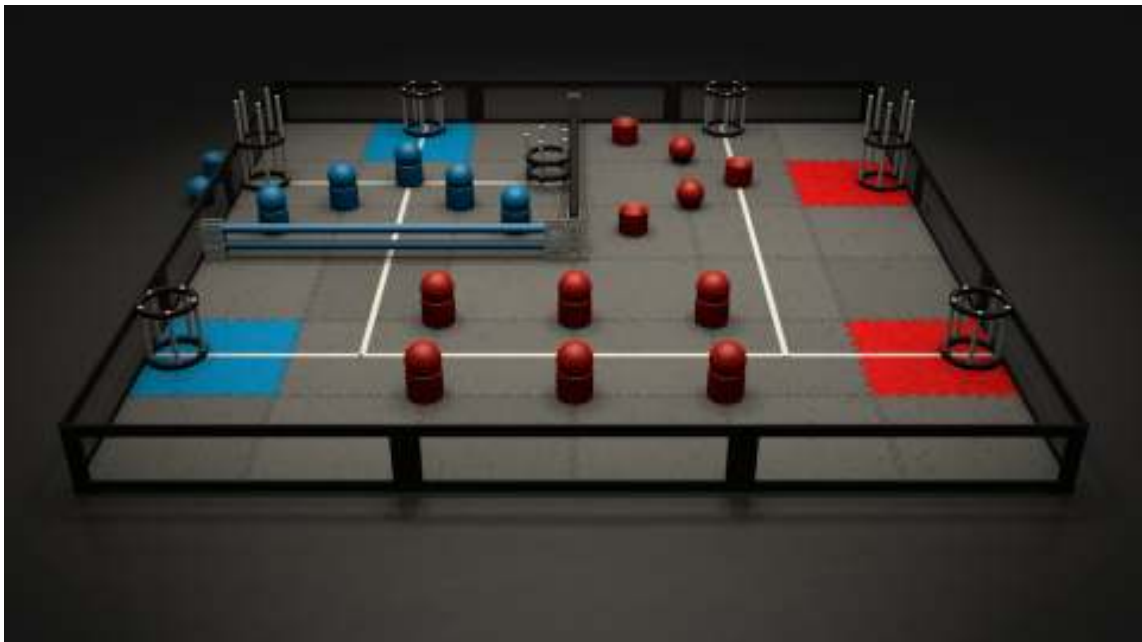

Field Diagrams

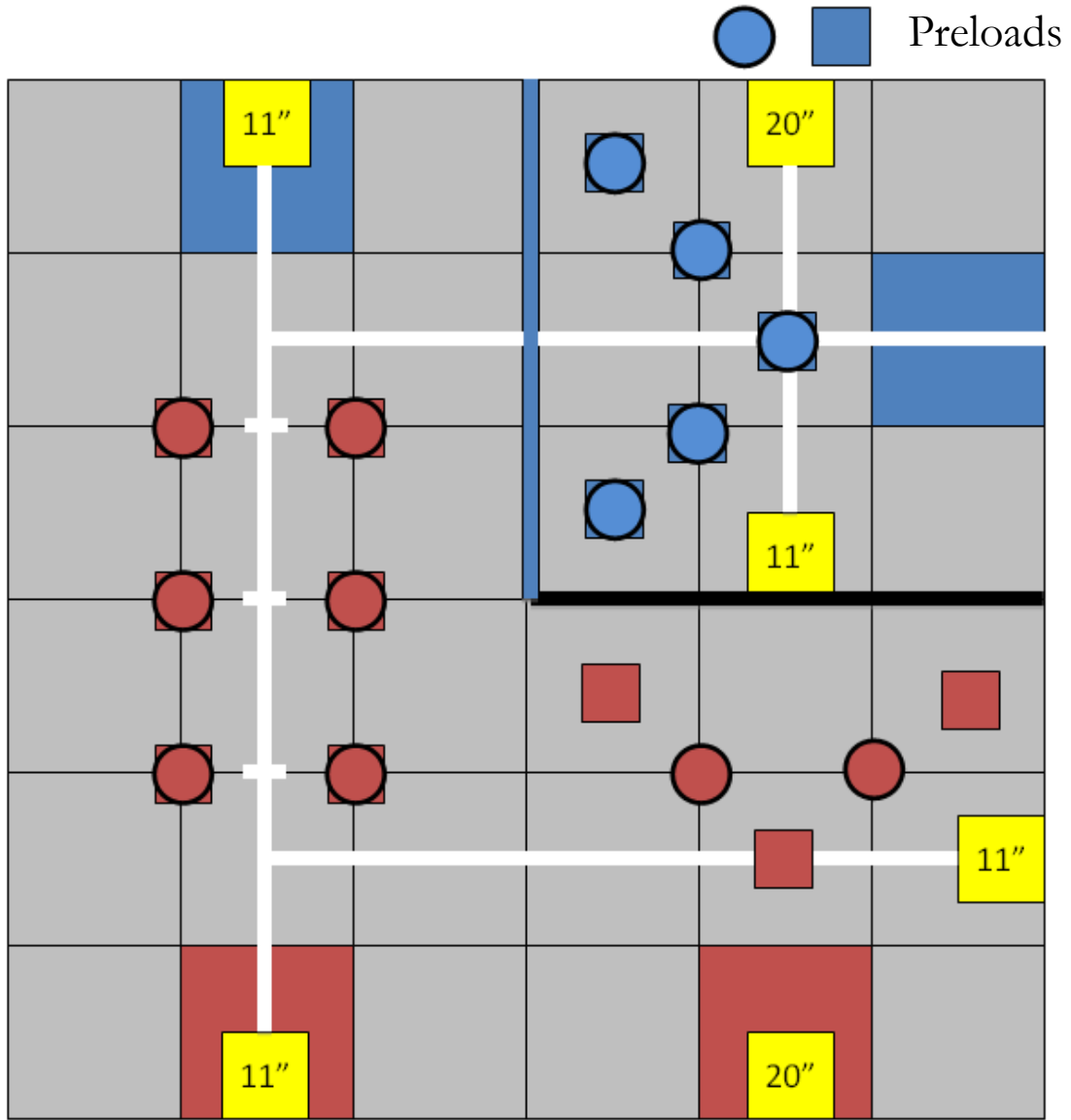

Full field diagram

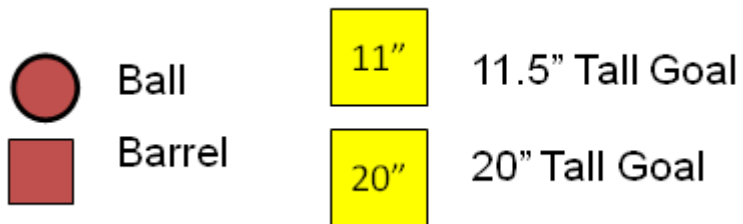

Full field diagram with dimensions

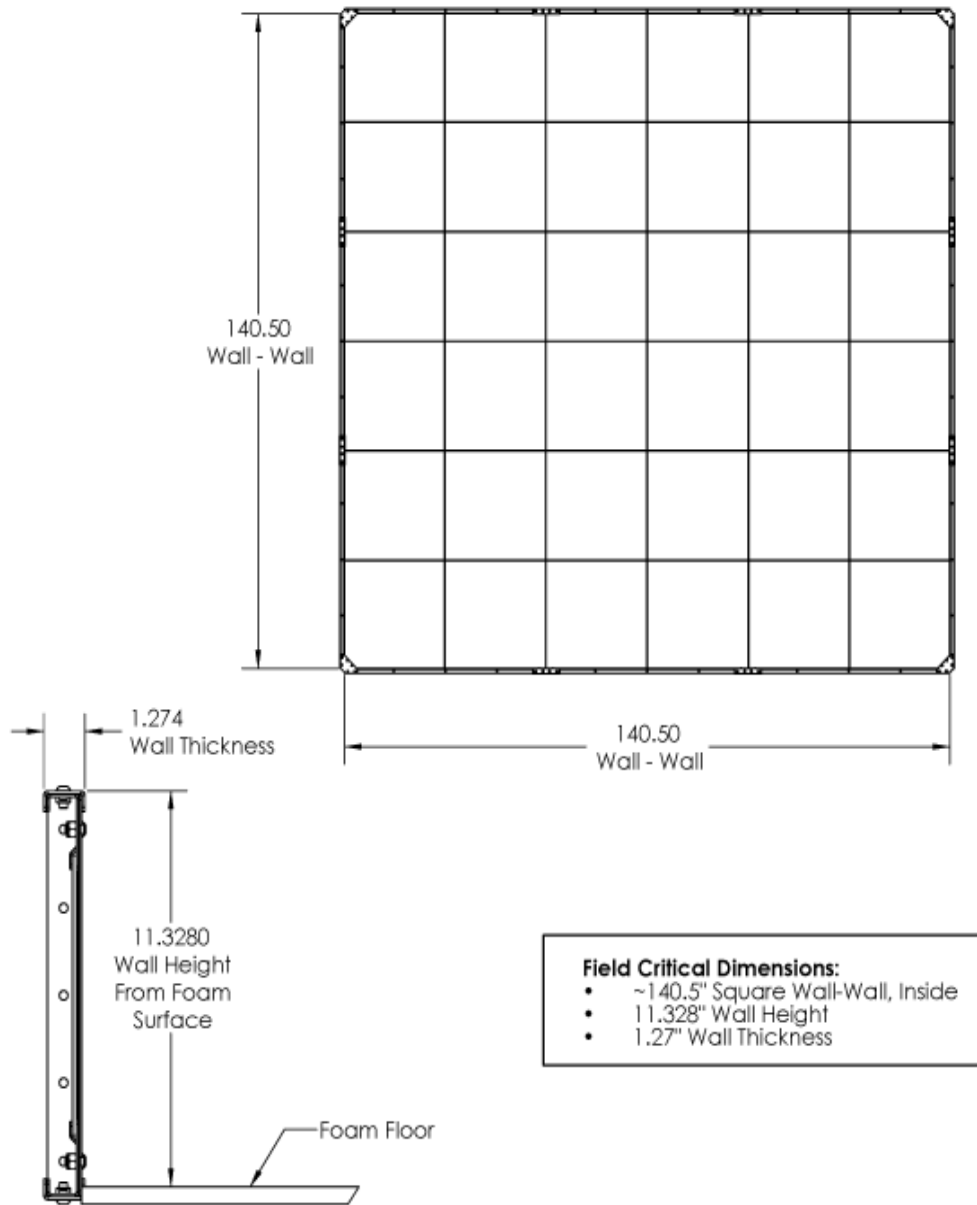

Playing surface and field border

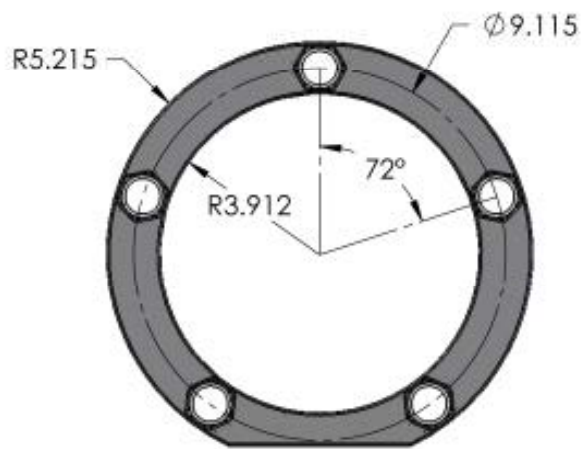
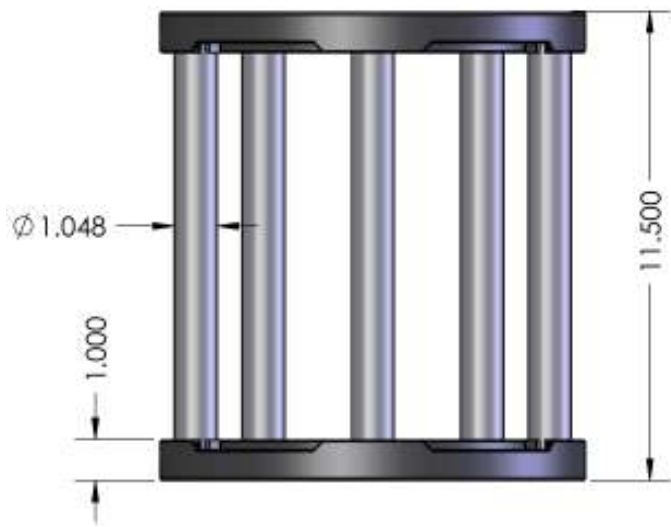

11.5" Circular Goal

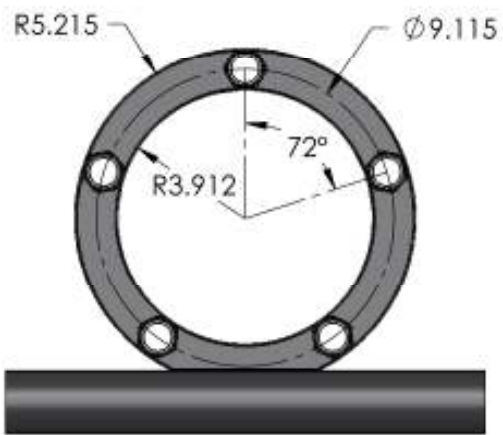
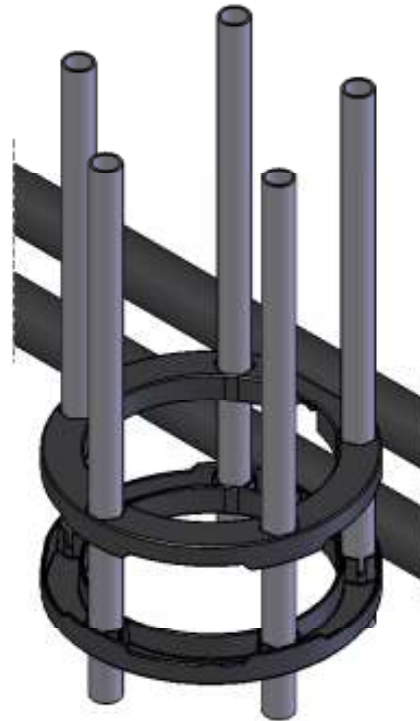
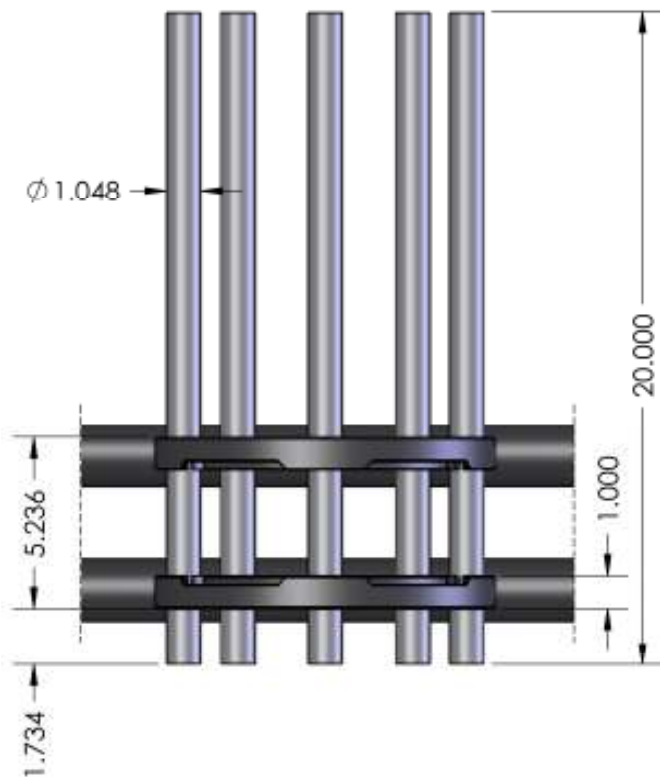

20" Circular Goal

Game Pieces

Ball

The balls are approximately six inches in diameter and are spherical. The balls are hollow and are made of hard plastic. A ball weighs approximately 0.25 pounds.

Barrel

The barrels are approximately six inches in diameter are five inches tall and are cylindrical. The ends of the barrels are concave so that a ball can rest on the top of bottom. A barrel weighs approximately 0.5 pounds. To purchase balls or barrels, please go to:

<http://www.VEXrobotics.com/products/competition-products/vrc-products/276-2102.html>.

Circular Goal

The circular goals either 11.5" or 20" inches tall and are 10.5" in diameter. The goals are made of two retaining rings holding five PVC pipes upright. To purchase this item, please go to:

<http://www.VEXrobotics.com/276-1355.html>.

Appendix C – State Competitions

Some State SkillsUSA competitions are held in smaller venues and are only four hours long. Because of this, the state director and their technical committees may choose to substitute or change the Mobile Robotics challenge in the following ways:

- Omit the math problem
- Omit an engineering change order
- Increase the number of rounds per team
- Omit the assembly period (allow teams to bring pre-assembled and ready to compete robots to the event)
- Use PIC microcontroller and crystals instead of Cortex microcontrollers and VEXnet

Please check with your SkillsUSA State Director and the associated technical committee for information regarding any modifications to the event as described in this document.

For more information on how to run, or find resources for a Mobile Robotics Competition in your state, please contact the Mobile Robotics national technical chair, Dan Larochelle at dlarochelle@intelitek.com.